

12V DC	F16-12L8201-06S F16-12L8201-06B	Suction-Aspirante Blowing-Soffiante							
Test Voltage: 13,0 VOLT DC									
Static Pressure Pa	IN H2O	SUCTION Aspirante				BLOWING Soffiante			
		Airflow m ³ /h	Airflow cfm/h	Current A	Eff. %	Airflow m ³ /h	Airflow cfm/h	Current A	Eff. %
0	0	1930	1140	14,4	-	1960	1160	14,5	0,0
50	0,2	1780	1050	15,1	-	1820	1070	15,3	12,7
100	0,4	1610	950	15,8	-	1660	980	15,9	22,3
150	0,6	1400	830	16,2	-	1440	850	16,5	28,0
175	0,7	1220	720	16,0	-	1320	780	16,7	29,5
200	0,8	1020	600	15,8	-	1190	700	16,9	30,1
250	1,0	760	450	16,5	-	850	500	17,4	26,1
300	1,2	610	360	17,3	-	630	370	17,7	22,8
350	1,4	440	260	17,7	-	420	250	17,8	17,6
400	1,6	290	170	18,3	-	240	140	18,8	10,9
450	1,8	130	80	19,0	-	110	60	20,0	5,3
500	2,0	0	0	20,0	-	0	0	21,1	0,0

24V DC	F16-24L8201-06S F16-24L8201-06B	Suction-Aspirante Blowing-Soffiante							
Test Voltage: 26,0 VOLT DC									
Static Pressure Pa	IN H2O	SUCTION Aspirante				BLOWING Soffiante			
		Airflow m ³ /h	Airflow cfm/h	Current A	Eff. %	Airflow m ³ /h	Airflow cfm/h	Current A	Eff. %
0	0	1920	1130	7,0	0,0	1900	1120	6,9	0,0
50	0,2	1770	1040	7,3	13,0	1760	1040	7,2	13,1
100	0,4	1600	940	7,6	22,5	1580	930	7,4	22,8
150	0,6	1390	820	7,7	28,9	1360	800	7,7	28,3
175	0,7	1180	700	7,5	29,3	1230	730	7,8	29,6
200	0,8	970	570	7,6	27,3	1090	640	7,8	29,9
250	1,0	750	440	7,9	25,4	760	450	8,0	25,4
300	1,2	600	350	8,2	23,5	540	320	8,2	21,1
350	1,4	440	260	8,5	19,4	340	200	8,3	15,3
400	1,6	290	170	8,7	14,2	170	100	8,8	8,3
450	1,8	120	70	9,0	6,4	50	30	9,3	2,6
500	2,0	0	0	9,4	0,0	0	0	9,6	0,0

ErP 2015 (2011/327/EC)							
RENDIMENTO - EFFICIENCY							
type	Pa	m3/h	A	kW	rpm	EFF.	r
Suction	-	-	-	-	-	-	-
Blowing	200	1190	16,9	0,22	3370	30,1%	1,0022

ErP 2015 (2011/327/EC)							
RENDIMENTO - EFFICIENCY							
type	Pa	m3/h	A	kW	rpm	EFF.	r
Suction	175	1180	7,5	0,20	3300	29,3%	1,0020
Blowing	200	1090	7,8	0,20	3260	29,9%	1,0022

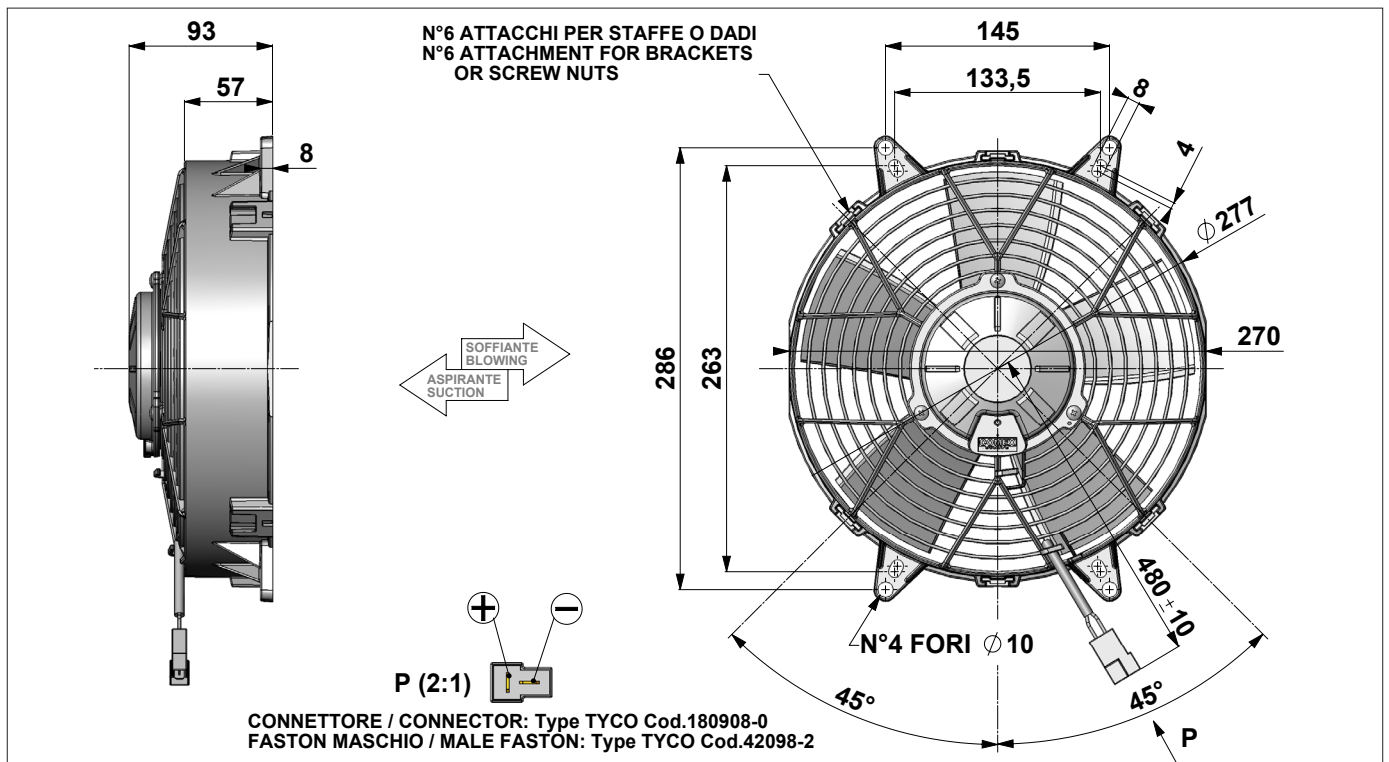

Weight: 2,4 Kg
Pressure rate: 1Pa = 0,004 inch H2O
Dimensions rate: 25,4 mm = 1 inch

Noise: LOW NOISE
Static Pressure: pascal (Pa)
Airflow rate: 1 m ³ /h = 0,59 cfm/h