

24V C.C. - D.C.

VA69A-B100-87A
VA69A-B100-87S

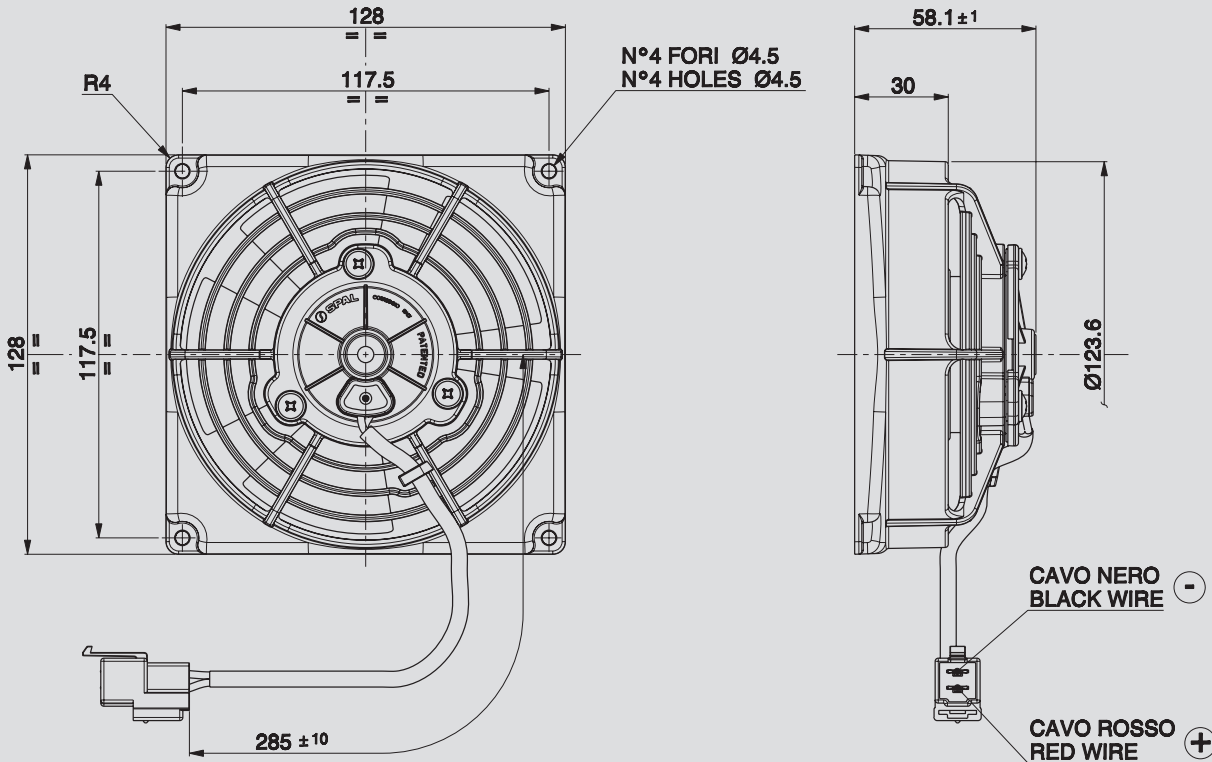

Suggested mounting torque: 3(+1/-0) Nm with screw M4
Weight 0.41 Kg. approx.

Coppia di serraggio consigliata: 3(+1/-0) Nm con vite M4
Peso 0,41 Kg. circa

Ø 115 mm
Ø 4.5"

suction / aspirante

blowing / soffiante

PRODUCT FEATURES
CARATTERISTICHE PRODOTTO

| Static pressure Pressione statica mm H ₂ O | suction / aspirante | | | blowing / soffiante | | | Static pressure Pressione statica in H ₂ O |
|---|--------------------------------------|--|------------------------|--------------------------------------|--|------------------------|---|
| | Airflow Portata m ³ /h | Current input Corrente assorbita A | Airflow Portata CFM | Airflow Portata m ³ /h | Current input Corrente assorbita A | Airflow Portata CFM | |
| 0 | 320 | 1,3 | 189 | 280 | 1,3 | 165 | 0 |
| 2,5 | 310 | 1,4 | 183 | 250 | 1,3 | 148 | 0,1 |
| 5 | 280 | 1,4 | 165 | 220 | 1,3 | 130 | 0,2 |
| 7,5 | 260 | 1,4 | 153 | 180 | 1,3 | 106 | 0,3 |
| 10 | 200 | 1,4 | 118 | 150 | 1,4 | 89 | 0,4 |
| 12,5 | 170 | 1,4 | 100 | 120 | 1,4 | 71 | 0,5 |
| 15 | 130 | 1,5 | 77 | 90 | 1,5 | 53 | 0,6 |
| 17,5 | 90 | 1,5 | 53 | 80 | 1,6 | 47 | 0,7 |
| 20 | 60 | 1,6 | 35 | 60 | 1,7 | 35 | 0,8 |
| 25 | 0 | 1,6 | 0 | 0 | 1,7 | 0 | 1 |

Waterproof motor, IP 68
Motore chiuso, IP 68



Waterproof connector
Connettori a tenuta stagna



✓ = Standard feature
Caratteristiche standard

✓ = Available upon request
Disponibile su richiesta

Test voltage 26 V. D.C. - Tensione di prova 26 V. c.c.