

24V C.C. - D.C.

VA31-B100-46A
VA31-B100-46S

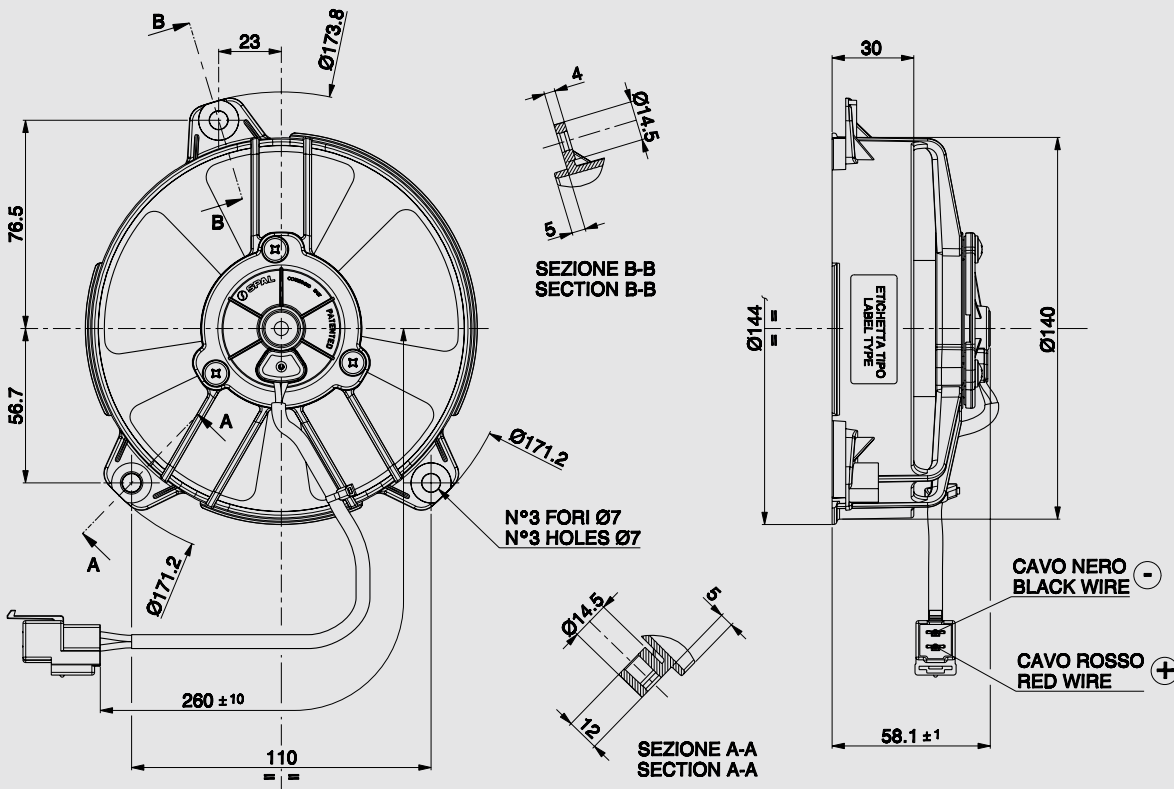

Connector SUMITOMO Code 6010-2802
SUMITOMO terminal Code 1800-2093
Suggested mounting torque: 3(+1/-0) Nm with screw M5
Weight 0.41 Kg. approx.

Connettore SUMITOMO Cod. 6010-2802
Terminali SUMITOMO Cod. 1800-2093
Coppia di serraggio consigliata: 3(+1/-0) Nm con vite M5
Peso 0,41 Kg. circa

Ø 130 mm
Ø 5,2"

suction / aspirante

blowing / soffiante

PRODUCT FEATURES
CARATTERISTICHE PRODOTTO

Static pressure Pressione statica mm H ₂ O	suction / aspirante			blowing / soffiante			Static pressure Pressione statica in H ₂ O
	Airflow Portata m ³ /h	Current input Corrente assorbita A	Airflow Portata CFM	Airflow Portata m ³ /h	Current input Corrente assorbita A	Airflow Portata CFM	
0	460	1,6	271	460	1,6	271	0
2,5	430	1,6	254	430	1,6	254	0,1
5	420	1,6	248	400	1,6	236	0,2
7,5	360	1,6	212	300	1,6	177	0,3
10	320	1,8	189	220	1,6	130	0,4
12,5	250	1,7	148	170	1,7	100	0,5
15	160	1,7	94	130	1,8	77	0,6
17,5	130	1,8	77	100	1,9	59	0,7
20	80	2,0	47	70	2,0	41	0,8
22,5	50	2,0	30	0	2,1	0	0,9
25	0	2,0	0				1

Waterproof motor, IP 68
Motore chiuso, IP 68



Waterproof connector
Connettori a tenuta stagna



✓ = Standard feature
Caratteristiche standard

✓ = Available upon request
Disponibile su richiesta

Test voltage 26 V. D.C. - Tensione di prova 26 V. c.c.